



2 PIECES SPLIT BODY STAINLESS STEEL BALL VALVES FLANGED PN16/40 DIN 3202-1 F4/F5

2 pieces stainless steel Split body ball valve with full bore for Chemical industries, petrochemical industries, hydraulic installation, heating, water distribution, compressed air.
 PTFE filled with 15% glass seat for a temperature up to +180°C.
 Double antistatic device.
 Handling possible with gearbox.
 Thanks to the ISO 5211 plate, an actuator can be installed on the valve.



- Size :** DN15 to DN150
- Connection :** Flanged PN16/40 RF
- Min Temperature :** -10°C
- Max Temperature :** +180°C
- Max Pressure :** 40 bars up to DN50, 16 bars over
- Specifications :** Double Antistatic device
 ISO 5211 mounting pad
 Anti blow-out stem, full bore
 PTFE filled with 15% glass seat

Materials : Stainless steel ASTM A351 CF8M



REF. 765

2 PIECES SPLIT BODY STAINLESS STEEL BALL VALVES FLANGED PN16/40 DIN 3202-1 F4/F5

SPECIFICATIONS :

- Full bore
- Anti blow-out stem
- Double antistatic device
- PTFE filled with glass seat
- Handle with locking device up to DN50
- ISO 5211 mounting pad
- 2 pieces type (Split body)
- Hollow ball for DN125 and DN150

USE :

- Chemical industries, petrochemical industries, hydraulic installation, heating and water distribution
- Min and max Temperature Ts : -10°C to + 180°C
- Max pressure Ps : 40 bars up to DN50, 16 bars over

RANGE :

- Ball valve with stainless steel body **Ref. 765** from DN 15 to DN 150

ENDS :

- R.F. flanges PN40 up to DN50, PN16 over

PRESSURE / TEMPERATURE GRAPH (STEAM EXCLUDED) :

Pressure (Bar)

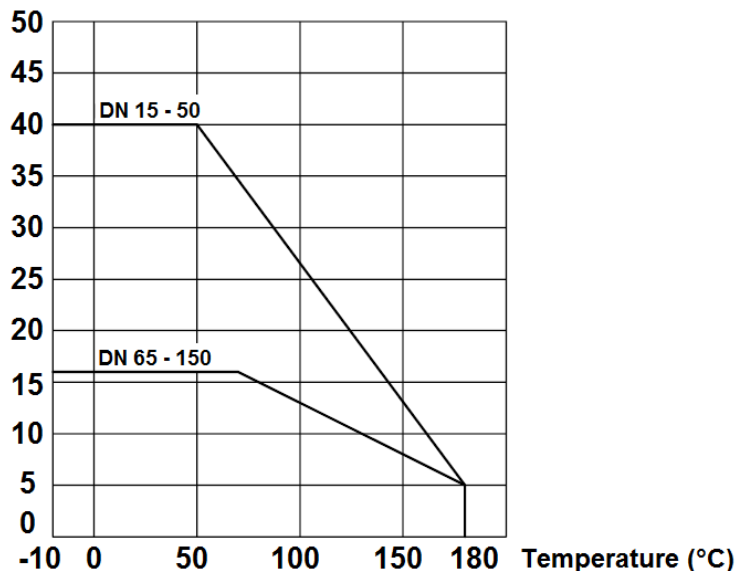

TORQUE VALUES (in Nm without safety coefficient) :

DN	15	20	25	32	40	50	65	80	100	125	150
Torque (Nm)	6	8	10	14	20	30	36	60	95	150	210



REF. 765

2 PIECES SPLIT BODY STAINLESS STEEL BALL VALVES FLANGED PN16/40 DIN 3202-1 F4/F5

MATERIALS DN 15 - 50 :

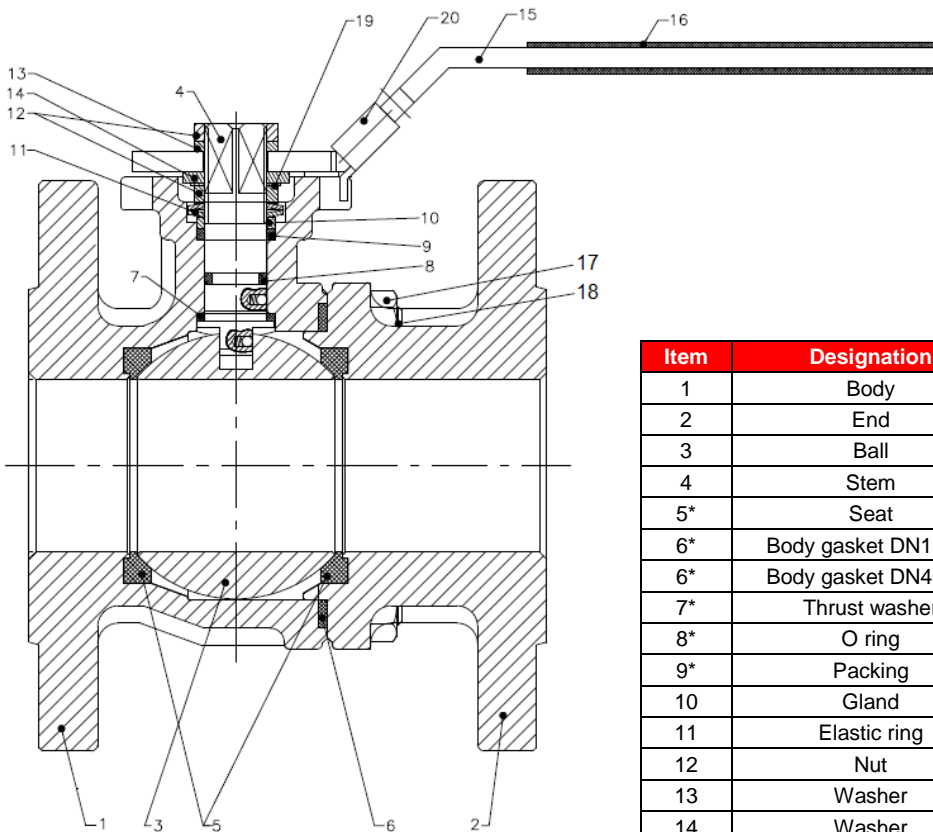

Item	Designation	Materials
1	Body	ASTM A351 CF8M
2	End	
3	Ball	AISI 316
4	Stem	
5*	Seat	PTFE filled with 3% glass fiber
6*	Body gasket DN15-32	PTFE filled with 15% graphite
6*	Body gasket DN40-50	AISI 304 + graphite
7*	Thrust washer	PTFE filled with 15% graphite
8*	O ring	FKM
9*	Packing	PTFE
10	Gland	AISI 304
11	Elastic ring	AISI 301
12	Nut	AISI 304
13	Washer	
14	Washer	
15	Handle	
16	Handle cover	Plastic
17	Nut	AISI 304
18	Stud bolt	
19	Spring washer	
20	Locking device	
21	Stopper	

(* : Included in gaskets kit)

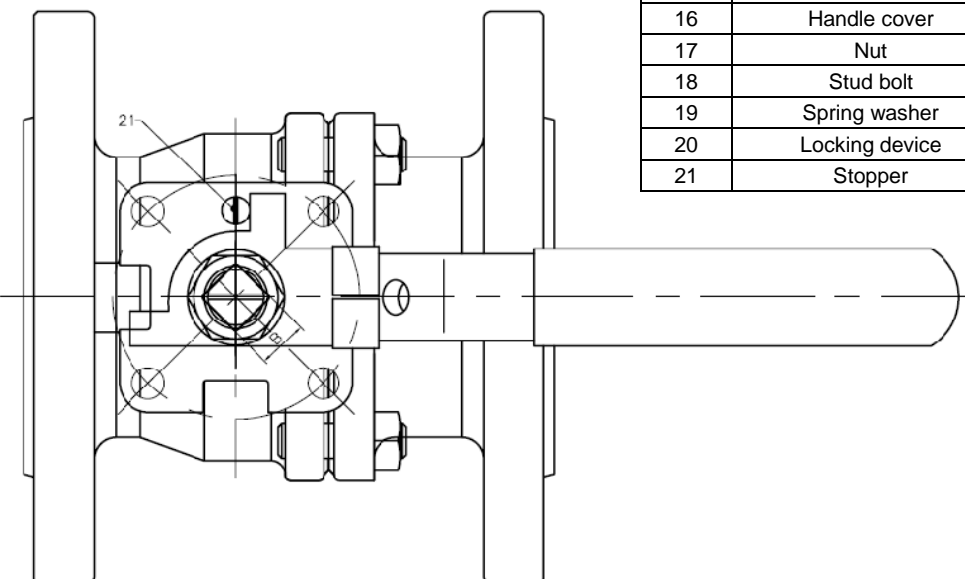



REF. 765

2 PIECES SPLIT BODY STAINLESS STEEL BALL VALVES FLANGED PN16/40 DIN 3202-1 F4/F5

MATERIALS DN 65 - 100 :

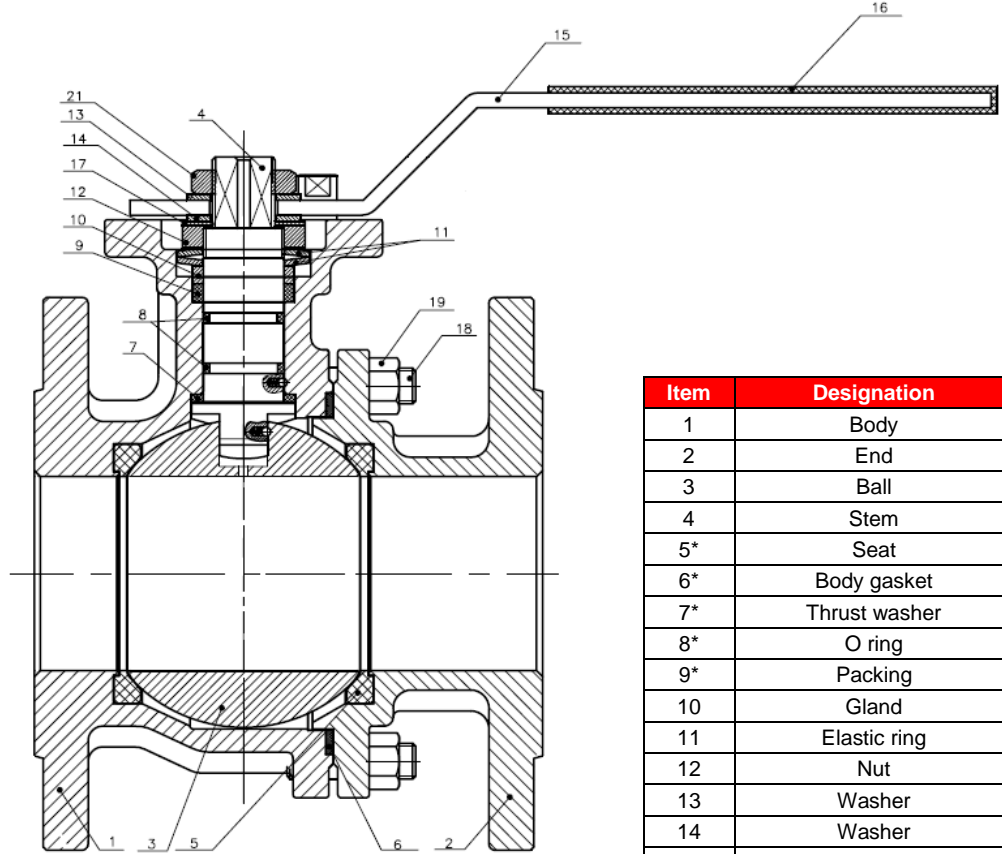

Item	Designation	Materials
1	Body	ASTM A351 CF8M
2	End	
3	Ball	AISI 316
4	Stem	AISI 316
5*	Seat	PTFE filled with 3% glass fiber
6*	Body gasket	AISI 304 + graphite
7*	Thrust washer	PTFE filled with 15% graphite
8*	O ring	FKM
9*	Packing	PTFE
10	Gland	AISI 304
11	Elastic ring	AISI 301
12	Nut	AISI 304
13	Washer	
14	Washer	
15	Handle	
16	Handle cover	Plastic
17	Spring washer	AISI 304
18	Stud bolt	
19	Nut	
20	Stopper	
21	Handle nut	

(* : Included in gaskets kit)

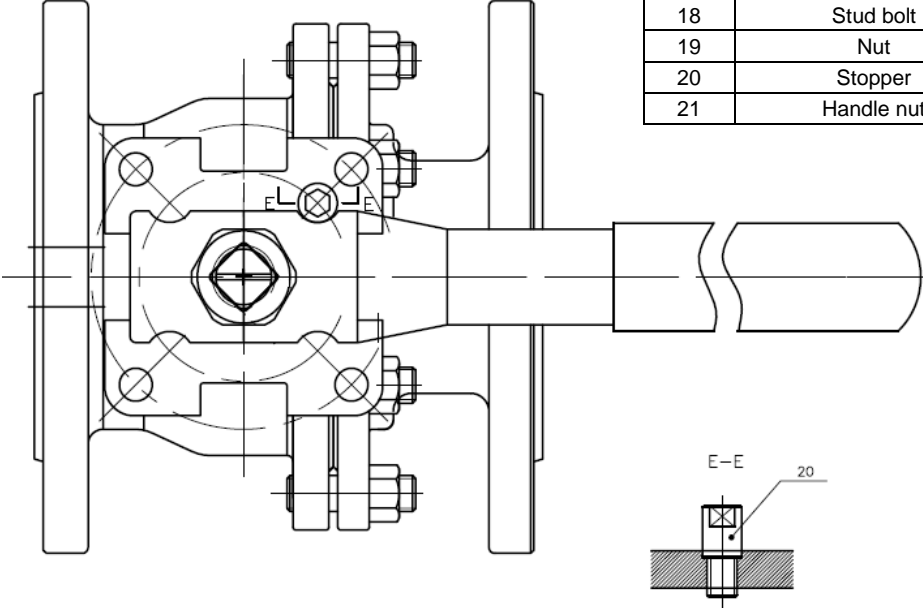



REF. 765

2 PIECES SPLIT BODY STAINLESS STEEL BALL VALVES FLANGED PN16/40 DIN 3202-1 F4/F5

MATERIALS DN 125 - 150 :

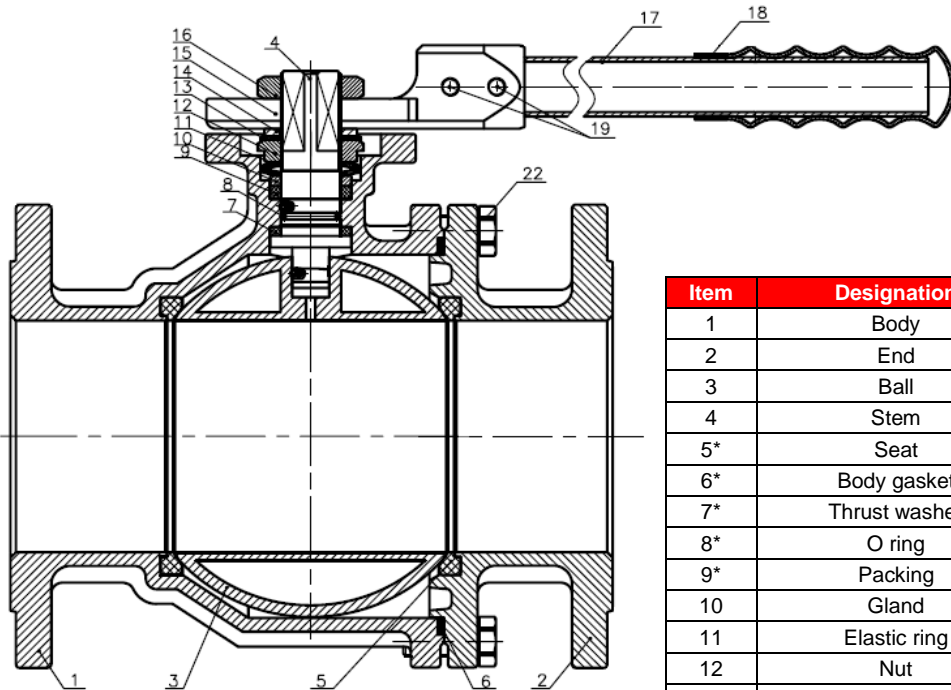

Item	Designation	Materials
1	Body	ASTM A351 CF8M
2	End	
3	Ball	
4	Stem	AISI 316
5*	Seat	PTFE filled with 3% glass fiber
6*	Body gasket	AISI 304 + graphite
7*	Thrust washer	PTFE filled with 15% graphite
8*	O ring	FKM
9*	Packing	PTFE
10	Gland	AISI 304
11	Elastic ring	AISI 301
12	Nut	ASTM A351 CF8
13	Spring washer	AISI 304
14	Washer	AISI 304
15	Handle adaptor	ASTM A351 CF8
16	Nut	ASTM A351 CF8
17	Handle	AISI 304
18	Handle cover	Plastic
19	Handle screw	AISI 304
20	Stopper	
21	Stopper nut	
22	Screw	

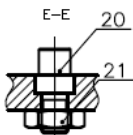
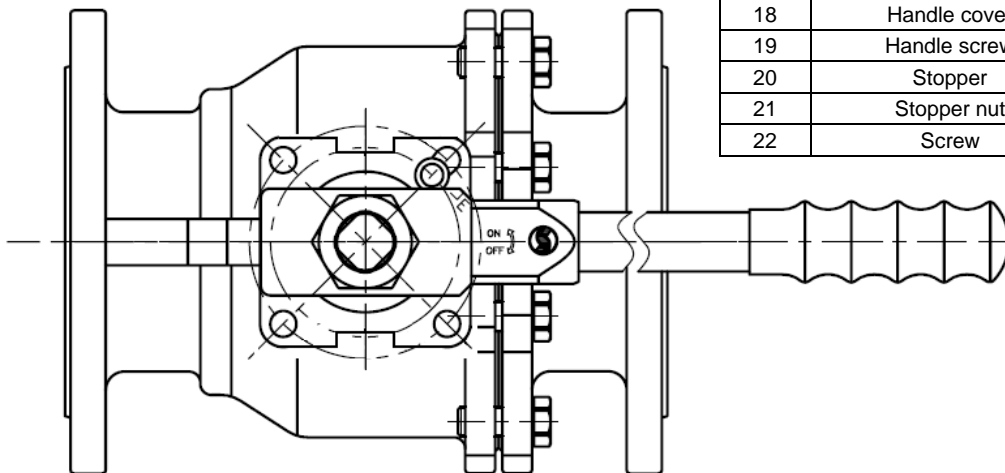

(* : Included in gaskets kit)



REF. 765

2 PIECES SPLIT BODY STAINLESS STEEL BALL VALVES FLANGED PN16/40 DIN 3202-1 F4/F5

SIZE DN 15 - 50 (in mm) :

DN 15 - 50

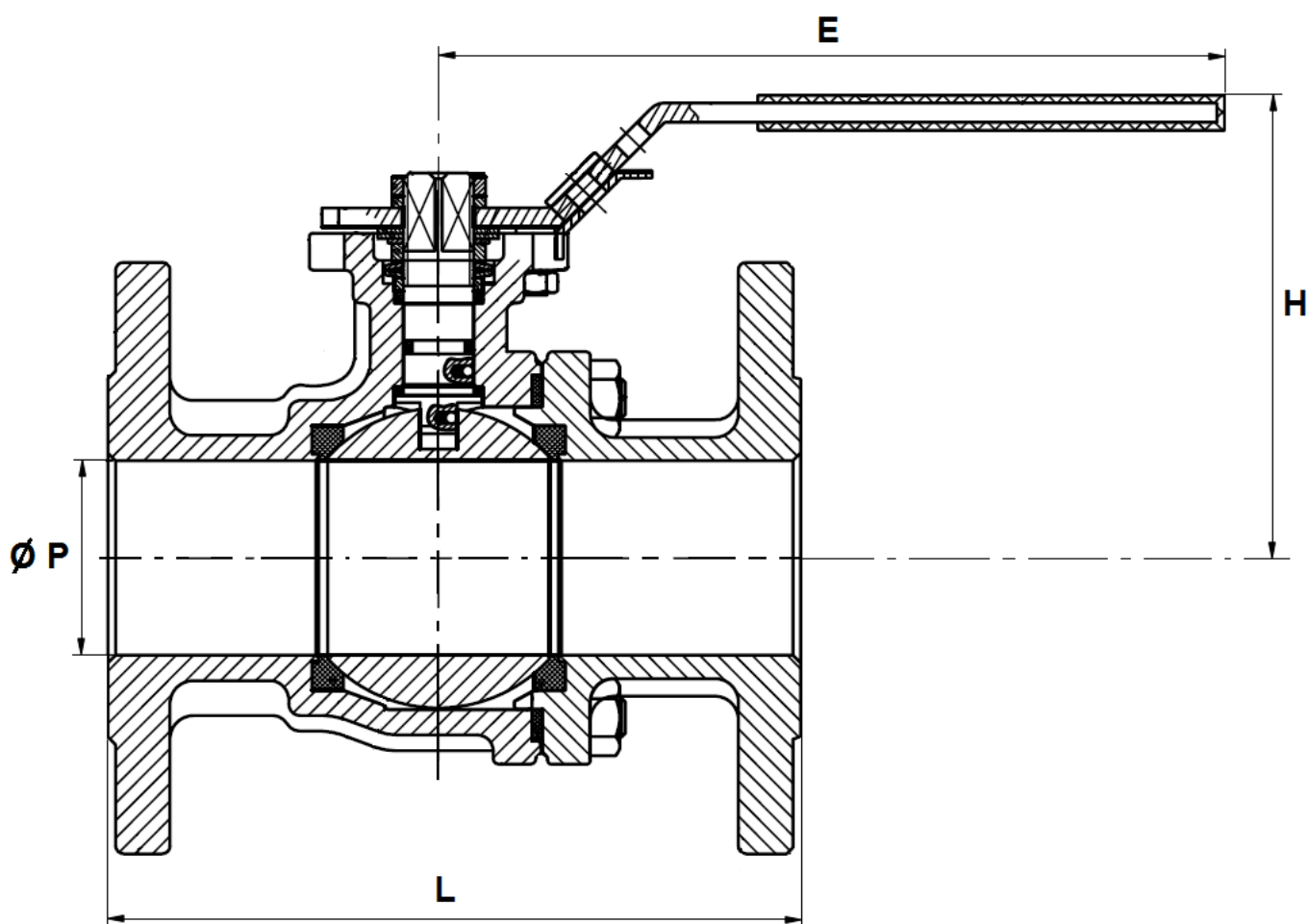

DN	15	20	25	32	40	50
Ø P	15	20	25	32	40	50
L	115	120	125	130	140	150
E	161.2	161.2	161.2	204.5	204.5	204.5
H	82.7	83.2	88.2	111	112	120
Weight (in Kg)	2.2	3.02	3.79	5.74	6.79	9.33
Ref.	765015	765020	765025	765032	765040	765050



REF. 765

2 PIECES SPLIT BODY STAINLESS STEEL BALL VALVES FLANGED PN16/40 DIN 3202-1 F4/F5

SIZE DN 65 - 100 (in mm):

DN 65 - 100

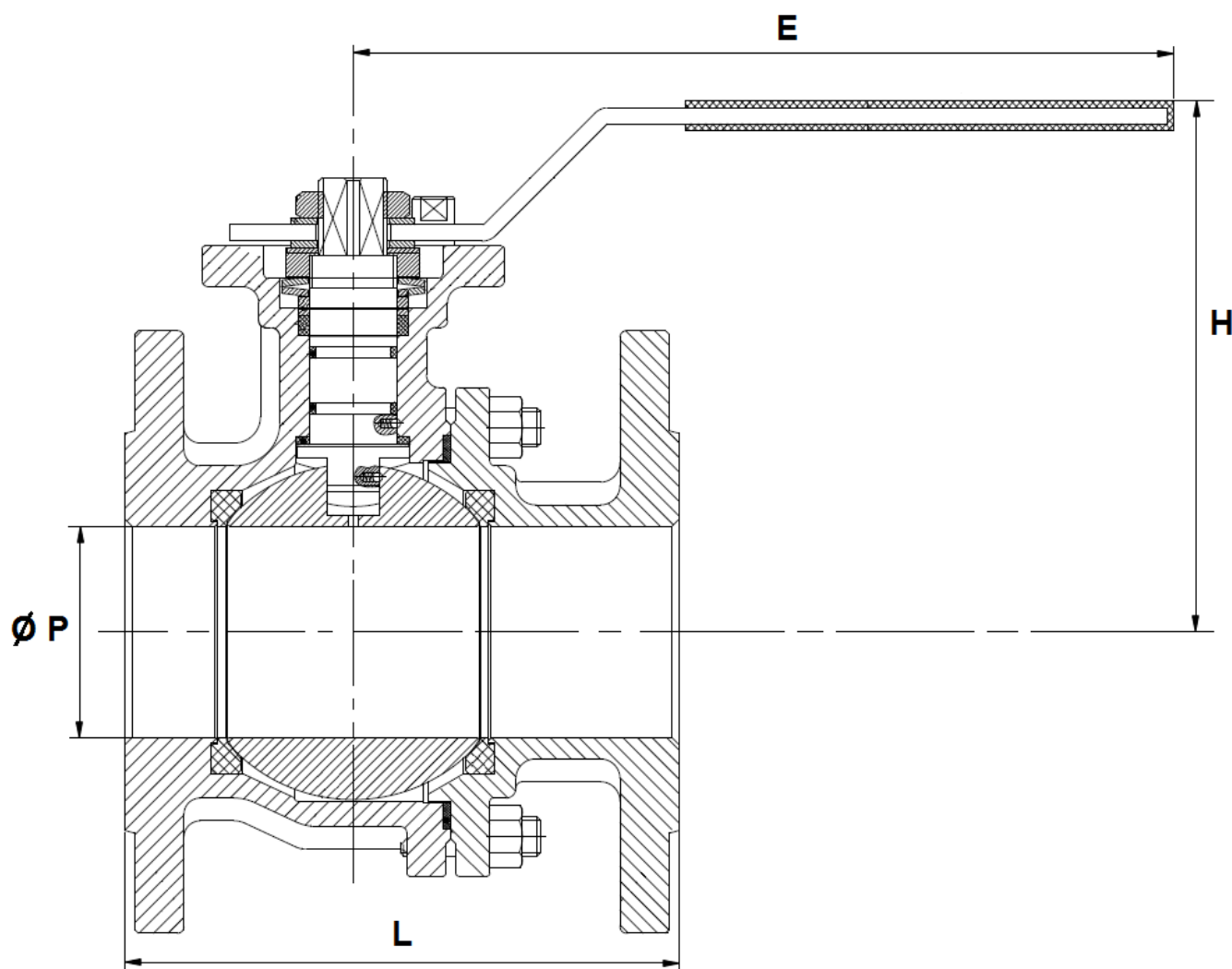

DN	65	80	100
Ø P	65	80	100
L	170	180	190
E	325	325	325
H	160	170	186
Weight (in Kg)	15.2	19.58	27.36
Ref.	765065	765080	765100



REF. 765

2 PIECES SPLIT BODY STAINLESS STEEL BALL VALVES FLANGED PN16/40 DIN 3202-1 F4/F5

SIZE DN 125 - 150 (in mm) :

DN 125 - 150

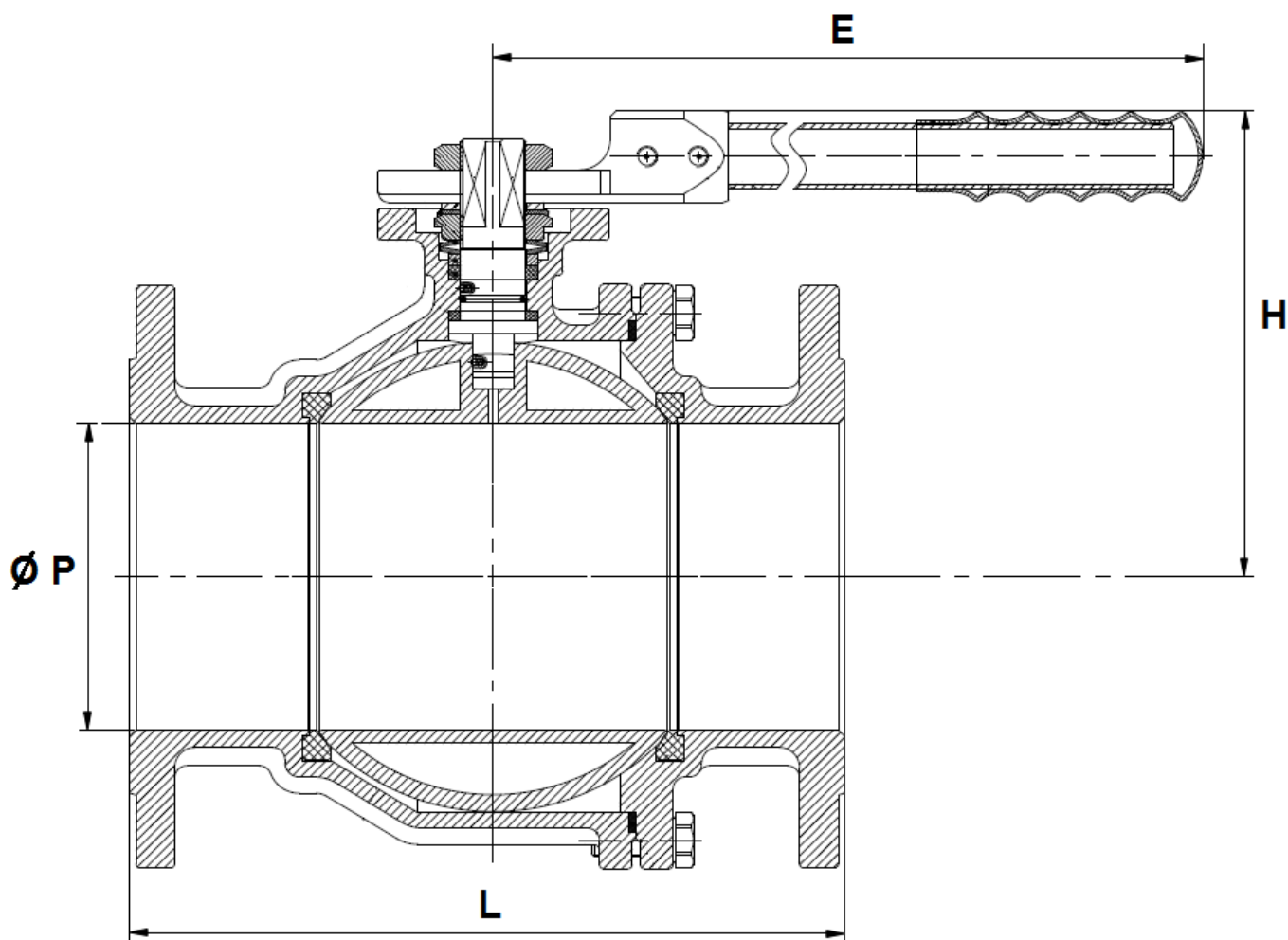

DN	125	150
Ø P	125	150
L	325	350
E	520	620
H	211	228
Weight (in Kg)	38.86	50.72
Ref.	765125	765150



REF. 765

2 PIECES SPLIT BODY STAINLESS STEEL BALL VALVES FLANGED PN16/40 DIN 3202-1 F4/F5

ISO MOUNTING PAD AND STEM SIZE (in mm) :

DN 15 – 50

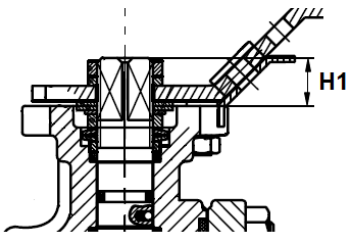

DN 65 – 100

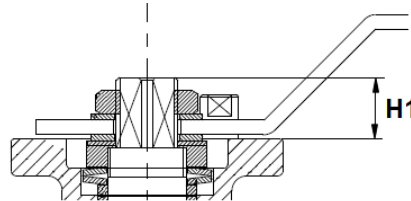

DN 125 – 150

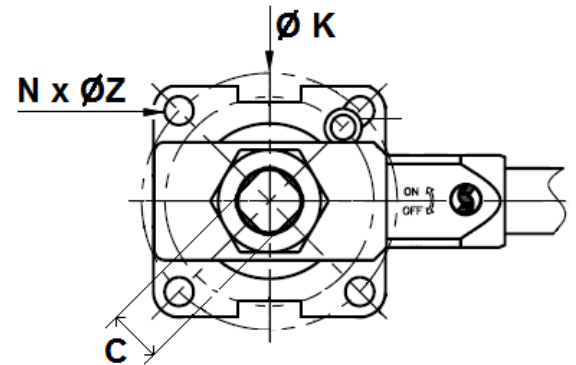
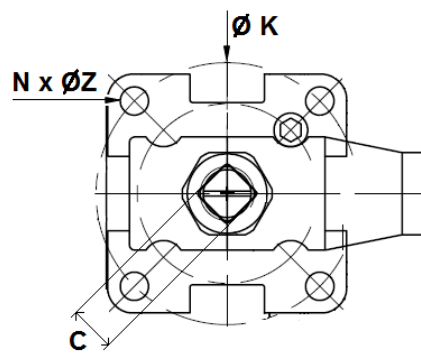
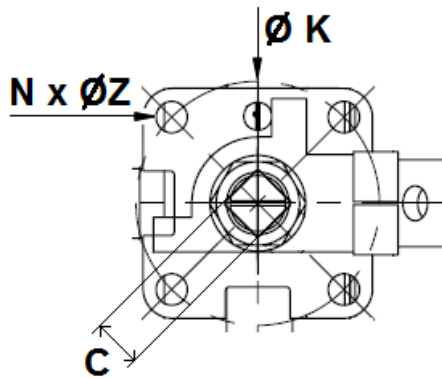
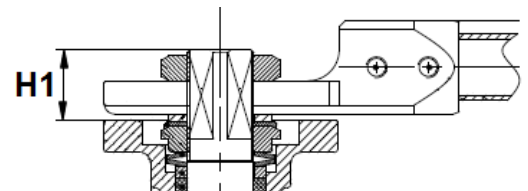

DN	15	20	25	32	40	50	65	80	100	125	150
C	9	9	11	14	14	14	17	17	17	27	27
Ø K	42	42	50	50	70	70	102	102	102	125	125
ISO	F04	F04	F05	F05	F07	F07	F10	F10	F10	F12	F12
N x Ø Z	4x6	4x 6	4x 7	4x7	4x9	4x 9	4x 11	4x 11	4x 11	4x14	4x14
H1	11	10	11	16.5	16.5	16.5	21	21	21	34	34



REF. 765

2 PIECES SPLIT BODY STAINLESS STEEL BALL VALVES FLANGED PN16/40 DIN 3202-1 F4/F5

FLANGES SIZE (in mm) :

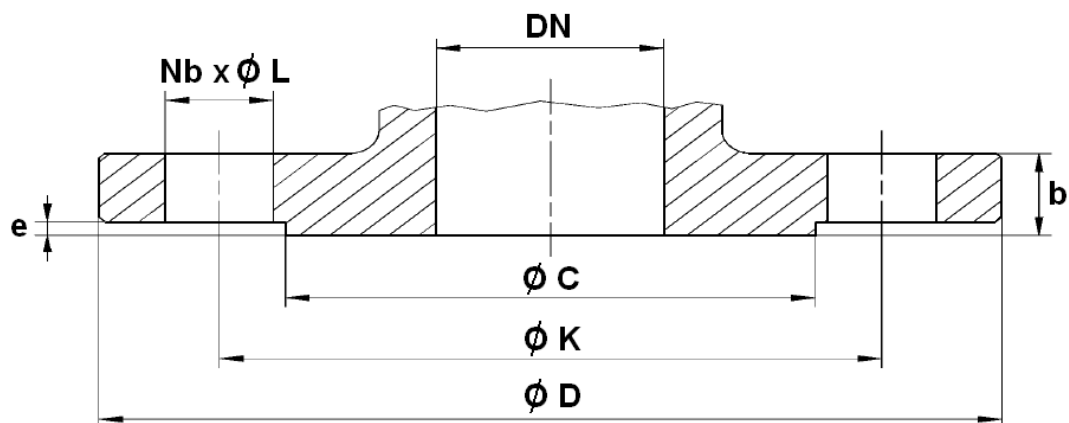

DN	15	20	25	32	40	50	65	80	100	125	150
Ø C	45	58	68	78	88	102	122	138	158	188	212
Ø D	95	105	115	140	150	165	185	200	220	250	285
Ø K	65	75	85	100	110	125	145	160	180	210	240
Nb x Ø L	4 x 14	4 x 14	4 x 14	4 x 18	4 x 18	4 x 18	4 x 18	8 x 18	8 x 18	8 x 18	8 x 22
b	16	18	18	18	18	20	18	20	20	22	22
e	2	2	2	2	3	3	3	3	3	3	3

**REF. 765****2 PIECES SPLIT BODY STAINLESS STEEL BALL VALVES FLANGED PN16/40 DIN 3202-1 F4/F5****STANDARDS :**

- Manufacturer certified ISO 9001 : 2015
- DIRECTIVE 2014/683/EU : CE N° 0035
Risk Category II module D1
- Certificate 3.1 on request
- Designing according to EN 12516-1
- Tests according to API 598, table 6
- Flanges R.F. according to EN 1092-1 PN16
- ISO 5211 mounting pad
- Length according to EN 558 series 27 (DIN 3202-1 F4 up to DN100, F5 over)

ADVICE : Our opinion and our advice are not guaranteed and SFERACO shall not be liable for the consequences of damages.
The customer must check the right choice of the products with the real service conditions.



2 PIECES SPLIT BODY STAINLESS STEEL BALL VALVES FLANGED PN16/40 DIN 3202-1 F4/F5

INSTALLATION INSTRUCTIONS

GENERAL GUIDELINES :

- Ensure that the valves to be used are appropriate for the conditions of the installation (type of fluid, pressure and temperature).
- Be sure to have enough valves to be able to isolate the sections of piping as well as the appropriate equipment for maintenance and repair.
- Ensure that the valves to be installed are of correct strength to be able to support the capacity of their usage.
- **Installation of all circuits should ensure that their function can be automatically tested on a regular basis (at least two times a year).**

INSTALLATION INSTRUCTIONS :

- **Before installing the valves, clean and remove any objects from the pipes** (in particular bits of sealing and metal) which could obstruct and block the valves.
- **Ensure that both connecting pipes either side of the valve (upstream and downstream) are aligned (if they're not, the valves may not work correctly).**
- **Make sure that the two sections of the pipe (upstream and downstream) match, the valve unit will not absorb any gaps. Any distortions in the pipes may affect the tightness of the connection, the working of the valve and can even cause a rupture.** To be sure, place the kit in position to ensure the assembling will work.
- **If sections of piping do not have their final support in place, they should be temporarily fixed. This is to avoid unnecessary strain on the valve.**
- Tighten the bolts in cross.
- Pressure tests should be done with cleaned pipes
- Pressure tests have to be done with partial opening. Pressure should not exceed valve specifications according to EN 12266-1 or API 598.
- Pressurizing should be done gradually to avoid water hammer.
- It's recommended to operate the valve (open and close) 1 to 2 times per year